

**CO1224F • 24" Combo® Model**

**FEATURES & BENEFITS**



STAINLESS SOLID



INTEGRATED SOLID



BLACK SOLID



WHITE SOLID

<b>PERFORMANCE</b>	<ul style="list-style-type: none"> <li>• Volume of 4.2 cu ft holds up to 61 bottles (12 oz) or 114 cans (12 oz)</li> <li>• Digital Touch Pad Control is conveniently located on upper face of unit</li> <li>• Refrigerator temperature range: 34°F - 45°F</li> <li>• Passive cooling system</li> <li>• Produces and stores up to 8 lbs of ice per day</li> <li>• Crescent ice cube dimensions: 1/2" W x 3/4" H x 2 1/4" L</li> <li>• Patented frost-free technology</li> </ul>
<b>INTERIOR/EXTERIOR</b>	<ul style="list-style-type: none"> <li>• White interior is illuminated with LED lighting</li> <li>• Three removable tempered glass shelves</li> <li>• Standard commercial stainless steel handle is interchangeable with professional handle accessory</li> <li>• No drain required</li> <li>• Door swing is field reversible</li> </ul>
<b>INTEGRATION</b>	<ul style="list-style-type: none"> <li>• Unit is designed to be built-in or can be freestanding with the freestanding accessory kit</li> <li>• Integrated model requires 3/4" custom door panel (panels not supplied by U-Line)</li> <li>• Four independently adjustable leveling legs provide a precise undercounter fit</li> <li>• Available in the following finishes: Stainless, Integrated, Black, or White</li> </ul>

**MODEL DETAILS**

Model	Voltage/Hz	Door Swing	Finish	Shipping Weight
U-CO1224FS-00B	115 / 60	Field Reversible	Stainless Solid	129 lb
U-CO1224FINT-00B	115 / 60	Field Reversible	Integrated Solid	126 lb
U-CO1224FB-00B	115 / 60	Field Reversible	Black Solid	129 lb
U-CO1224FW-00B	115 / 60	Field Reversible	White Solid	129 lb

**ACCESSORIES**

Model	Description	Finish	Shipping Weight
80-54247-00	Professional Door Handle, 1 1/4" Diameter	Stainless	2 lb
80-54214-00	Commercial Door Handle, 7/8" Diameter	Stainless	2 lb
U-FSK-B	Freestanding Kit	Black	3 lb
80-54674-00	Braided water supply line kit	N/A	2 lb

**24" Combo® Model • CO1224F**
**DIMENSIONS**

Dimensions shown apply to all finishes, including Integrated (INT) models with 3/4" integrated panel/frame installed.

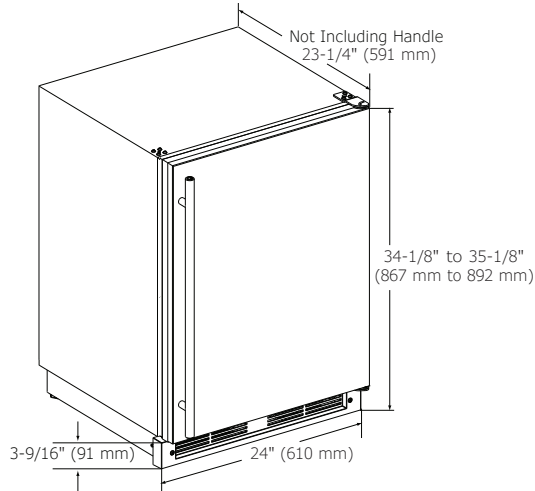
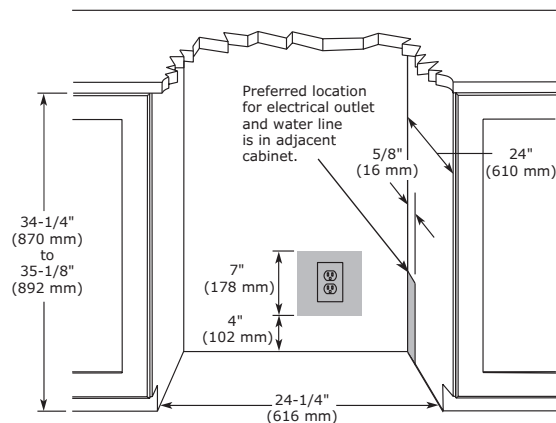
**CABINET CUT-OUT**

**INSTALLATION NOTES**

When installing adjacent to wall, ensure 2 1/2" clearance on hinged side for 90° door opening, allowing ample room for door handle.

Cutout includes the additional 1/4" width overall to ensure proper installation.

No additional clearance around sides, top or rear of unit is needed for ventilation.

Do not obstruct front grille air flow.

**SPECIFICATIONS**

Model	CO1224F
Amps: Running	2.4
Capacity: Bottle (12 oz)	61
Capacity: Can (12 oz)	114
Capacity: Refrigerator Volume (cu ft)	4.2
Control Type	Digital Touch Pad
Defrost Type	Frost Free
Dimensions: Product Depth	23 1/4" / 591 mm
Dimensions: Product Height	34 1/8" / 867 mm
Dimensions: Product Width	24" / 610 mm
Energy Consumption: Avg. Per Year	579 kWh
ENERGY STAR	No
Ice Production Per Day	8 lb
Ice Storage	8 lb
Panel Height	30 1/4" / 768 mm
Panel Thickness	3/4" / 20 mm
Panel Type	Solid Panel
Panel Width	23 3/4" / 603 mm
Product Weight: Max	119 lb
Refrigerant Type	R134A
Sabbath (Star K Certified)	Yes
Temperature Range	34°F - 45°F

**ELECTRICAL REQUIREMENTS**

This unit requires a grounded, polarized 115 VAC, 60 Hz, 15 A power supply (normal household current).



Residential

Please visit [U-Line.com](http://U-Line.com) to view this model's User Guide. All specifications are subject to change without notice.