

INSTALLATION INSTRUCTIONS
ELECTRICAL AIR SWITCH
MODEL No's: III

NEWPORT BRASS®
Flawless Beauty. From Faucet to Finish.™

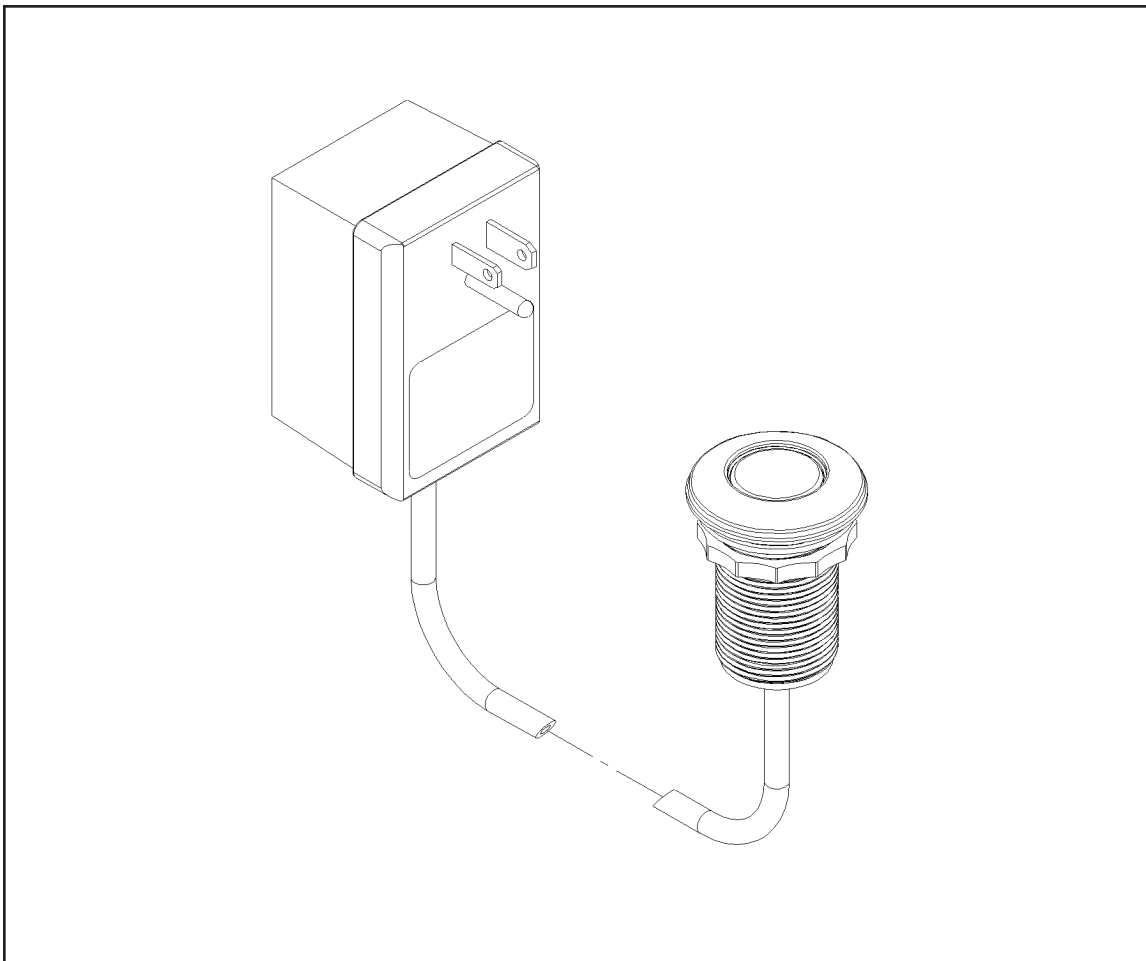

General

This control system provides safe and convenient remote on/off switching of one 120V load. Contents: Controller, Air transmitter and air hose.

Operation

The control system works on a sealed air displacement principle. As the air transmitter button is depressed and released, sealed air is displaced and transmitted through the interconnecting air hose to the pressure sensitive electrical switch, completing the electrical circuit and turning the disposer on. The circuit will remain energized until the air transmitter is depressed and released again, turning the disposer off.

Caution

To avoid damage to this equipment or equipment being controlled, **DO NOT** cycle rapidly or connect other equipment to outlet with disposer.

Electrical rating

15 AMPS (non-inductive) @ 120 VAC

Read all instructions before installing control system.

1. System must be mounted within 6' of controller outlet. Select a location which is both convenient to user and accessible for service and removal.
2. Drill a $\varnothing 1.25$ " hole at mounting location. Transmitter body will accommodate surfaces 1/16" to 2" thick.
3. Remove mounting nut from transmitter. Insert body of transmitter through mounting hole and secure in place with mounting nut.
4. Connect one end of air hose to transmitter fitting. Safely route hose and connect to controller fitting.
5. Plug the controller into a dedicated, grounded 120 VAC outlet which is continuously energized.
6. Plug the disposer into the controller. (Caution: The disposer may begin to operate, if so press and release air transmitter button to turn disposer off.
7. Ensure that the controller system is operating properly before using the disposer. Press and release air transmitter button to turn the disposer on. Press and release the air transmitter to turn the disposer off.

Select transmitter location
(Max. 6 ft. from controller)

Dedicated, grounded 120 VAC outlet,
continuously energized

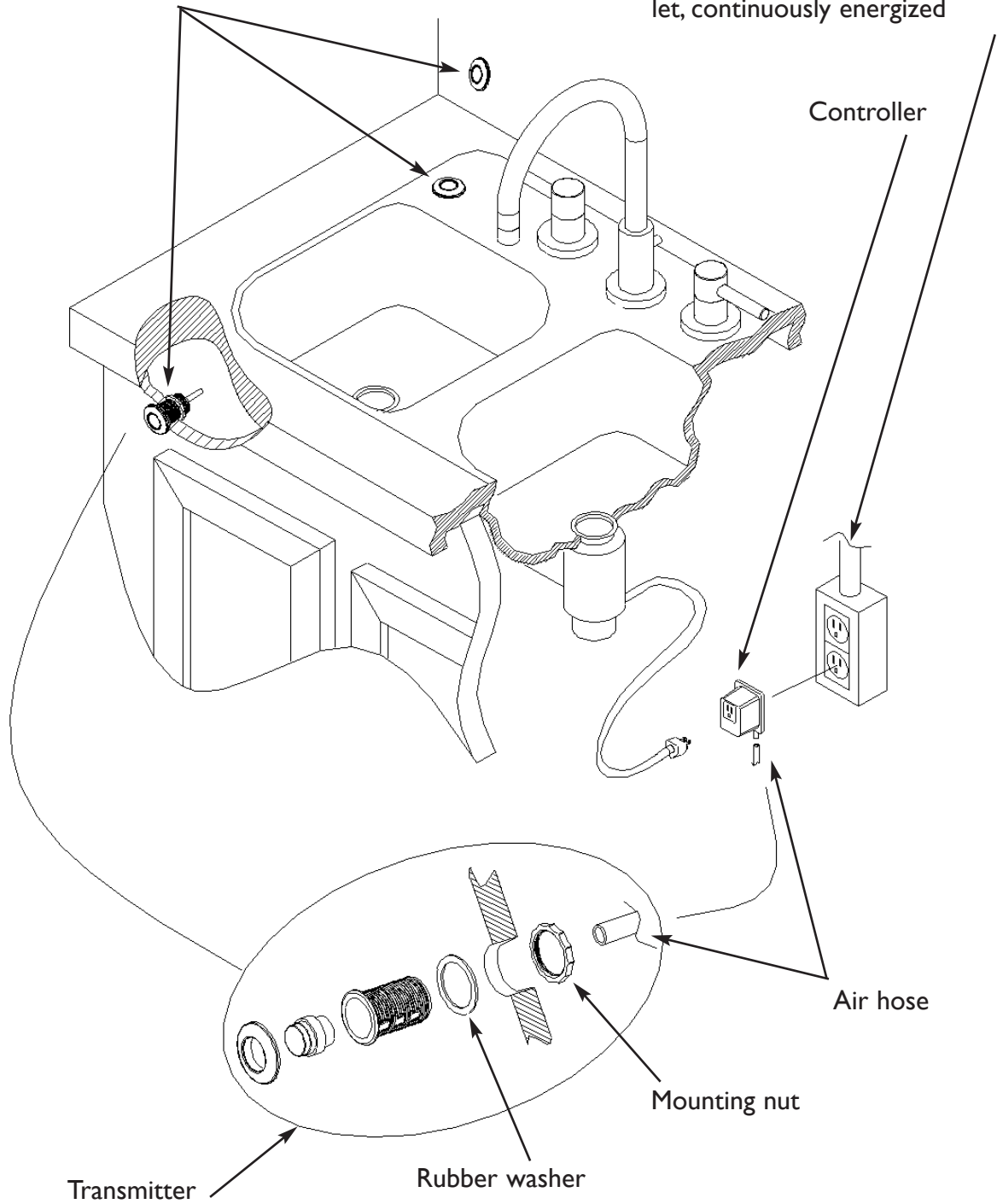

Warning: To avoid risk of injury

- Use indoors in dry locations only.
- Do not exceed specified electrical ratings.
- Do not crimp or damage the interconnecting air hose.
- No user serviceable components inside of controller.
- Opening controller will void manufacturer's warranty

(949) 417-5207

Santa Ana, Ca. 92705

www.newportbrass.com

NWP-111

12/28/17